

Taper Lock Rigid Couplings provide a convenient method of rigidly connecting ends of shafts. Taper Lock bushes permit easier and quicker fixing to the shafts with the firmness of a shrunk-on-fit. These

couplings have a male and female flange fully machined. The male flange can have the bush fitted from the Hub side **H** or from the Flange side **F**, the female flange always has the bush fitting **F**. This gives

two possible coupling assemblies **HF** and **FF**. When connecting horizontal shafts, the most convenient assembly should be chosen. **When connecting vertical shafts use assembly FF only.**

## SELECTION

For all applications using standard mild steel shafting it is sufficiently accurate to select the coupling by consideration of bore size alone.

If transmitted torque is known, this should be checked against the allowable torque for the appropriate Taper Lock bush size/bore shown on page 128.

For all other applications consult your local Authorised Distributor.

Rotational speed should be limited to a maximum rim speed of 33 m/sec.

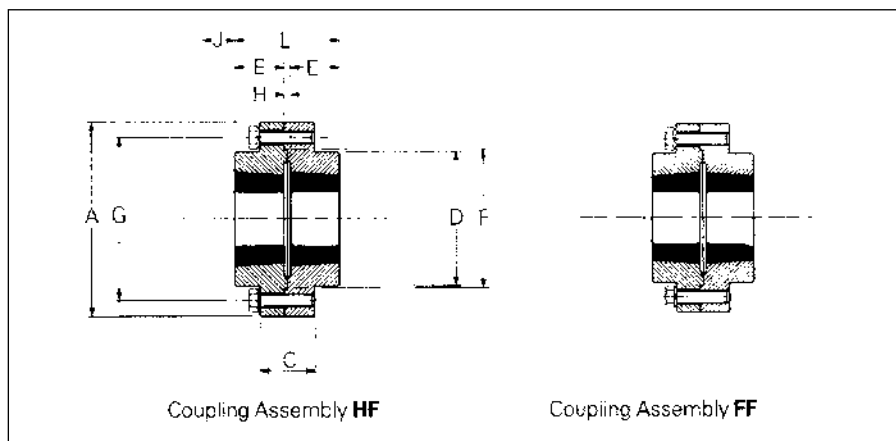
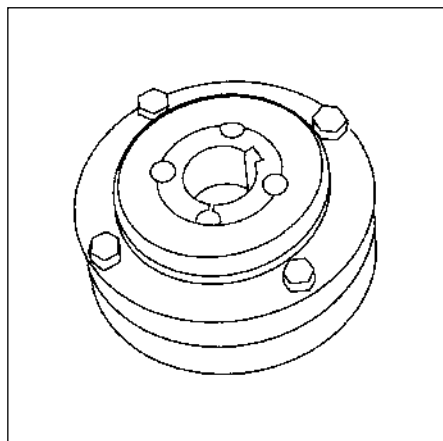

## DIMENSIONS

Size	Bush No.	Max. Bore		A	C	D	E	F nominal	G nominal	H†	J*	L	Mass‡ (kg)
		Metric	Inch										
<b>RM12</b>	1210	32	1 1/4"	118	35	83	25	76	102	7	38	57	3.5
<b>RM16</b>	1610	42	1 5/8"	127	43	80	25	89	105	7	38	57	4.0
<b>RM25</b>	2517	60	2 1/2"	178	51	123	45	127	149	7	48	97	11.0
<b>RM30</b>	3020	75	3"	216	65	146	51	152	181	7	54	109	20.0
<b>RM35</b>	3525	100	4"	248	75	178	65	178	213	7	67	137	34.0
<b>RM40</b>	4030	110	4 1/2"	298	76	210	76	216	257	7	79	159	59.0
<b>RM45</b>	4535	125	5"	330	86	230	89	241	286	7	89	185	80.0
<b>RM50</b>	5040	125	5"	362	92	266	102	267	314	7	92	211	135.0

All dimensions in millimetres unless otherwise stated.

\* J is the wrench clearance to allow for tightening and loosening the bushing on the shaft. The use of a shortened wrench will permit this dimension to be reduced.

† H is the distance between shaft ends.

‡ Masses given are for couplings with mid-range bore Taper Lock Bushes.

## CODE NUMBERS

Size	Catalogue Code HF	Catalogue Code FF
RM12	039A0501	039A0502
RM16	039B0501N	039B0502N
RM25	039C0501	039C0502
RM30	039D0501N	039D0502N
RM35	039E0501N	039E0502N
RM40	039F0501N	039F0502N
RM45	039G0501N	039G0502N
RM50	039H0501N	039H0502N